

Unique, high-performance
optical sorter

SORTOP POTATOES

VP02-UW

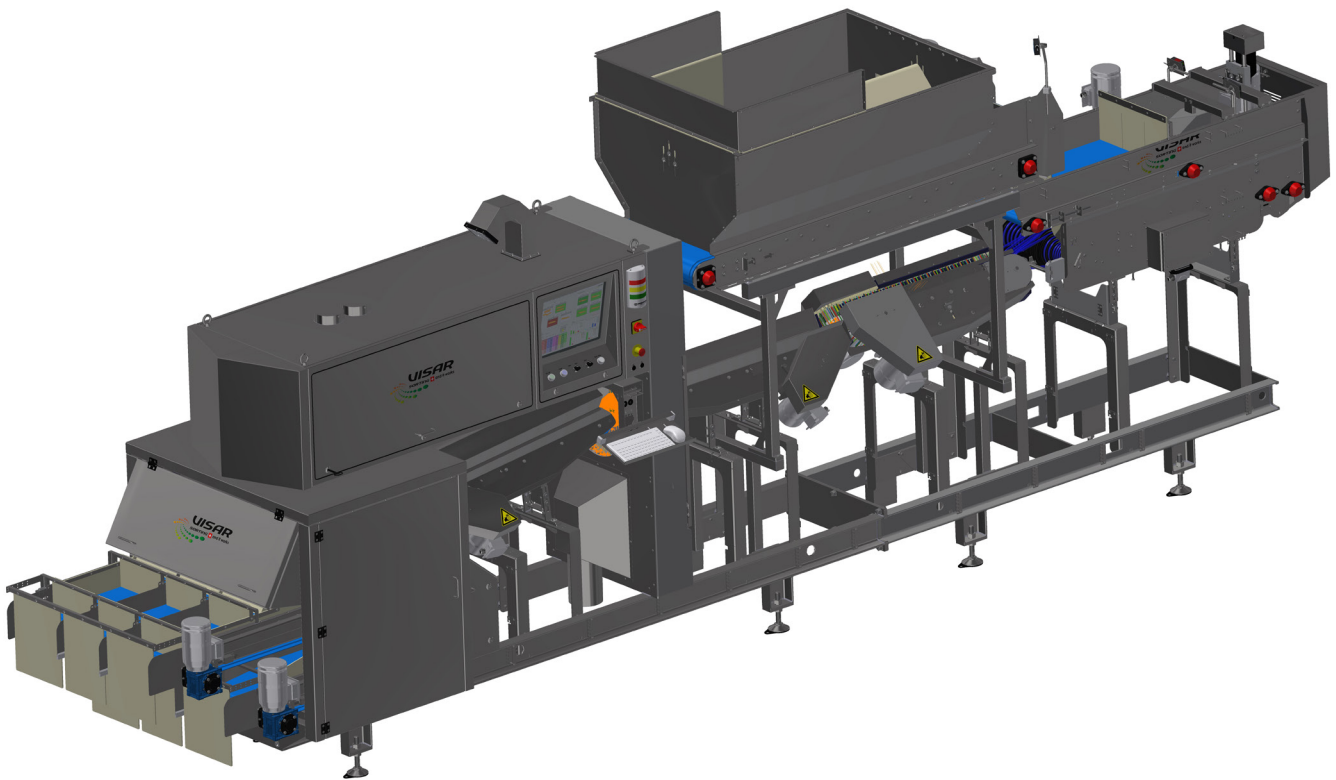

Your advantages:

- Worldwide unique, intelligent software
- Highly precise calibration (diameter, length and weight)
- 6 outputs, customized solutions
- 360 ° HD analysis, unsurpassed sorting quality
- Maximum profitability and efficiency

Intelligent software - acts as a human being

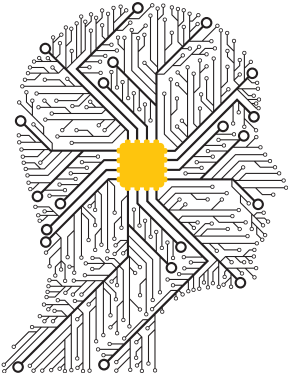

The principle is based on artificial intelligence, which enables the subjective evaluation of the quality, shape and appearance of each potatoe and thereby **replicates the human appreciation**. Combined with other measurable criteria (the slightest defects such as wireworm damage for example), this setting allows the fine-tuning of the sorting accuracy.

- Statistics function
- Complete traceability of each batch
- Perfect integration of the computer and the electrical control built into a waterproof control cabinet

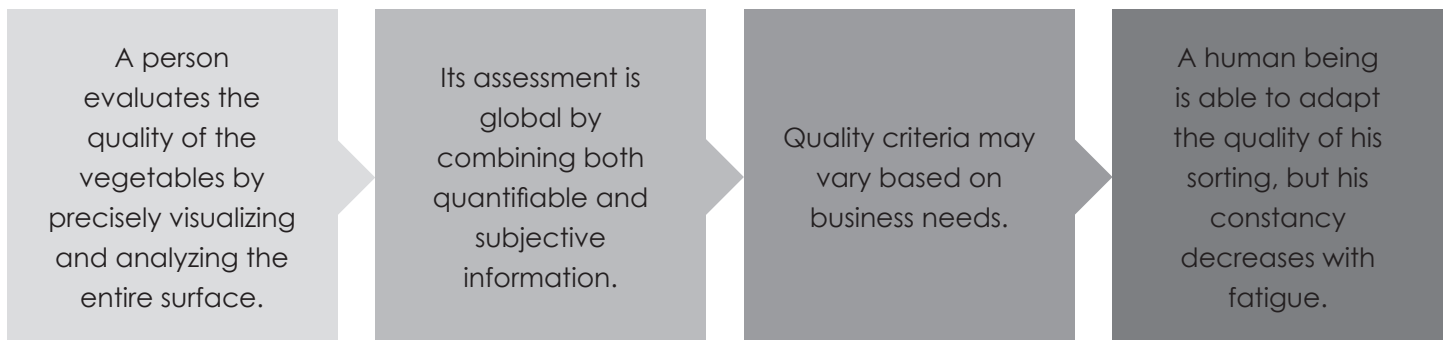

The machine is able to reproduce the work of a human more consistently and more efficiently.

The machine for unwashed potatoes

The software Visar VACS sorts unwashed potatoes without a problem. The mechanical elements are designed to resist dust.

Feeding system - robust & reliable

A robust belt system aligns potatoes of all sizes, smoothly and almost without any duplicates.

The sorting capacity is between 1.5 and 4 tons per hour depending on the average size of the potatoes.

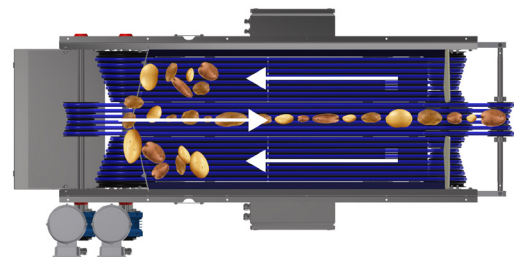

Optical system - highly precise 360° analysis

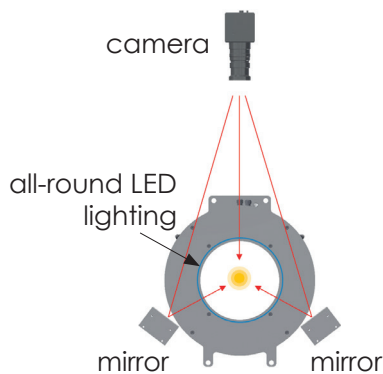

Thanks to a mirror system and a very powerful all-round lighting that eliminates shadows, **every vegetable is subjected to a perfect 360° analysis.** The optical system generates 3 immaculate high-resolution images of each carrot. These can be displayed immediately on the computer screen to check the error detection.

- High-resolution color and infrared camera, error detection from 0.16 mm²
- Calibration accuracy at 20 to 90 mm square mesh grading; calibration by the weight of each tuber with a 5% accuracy
- **Visualization of images with display of error detection**
- Accepts all shapes of potatoes

5 quality levels

The software allows an easy setting of 5 quality levels (plus waste). The volume and value of the product sold is increased and waste is reduced to a minimum. Thanks to the accuracy of the setting and the unique sorting consistency of the software, **a significantly higher yield per batch is achieved.**

Ejection - gently & exactly

A nozzle system blows the potatoes towards the assigned outputs with extreme precision. The fall is cushioned by soft materials that **guarantee a smooth landing.**

Up to 6 outputs

The machine is equipped with 6 outputs: 5 of them can be freely parameterized and one is used for the waste. The products of each exit are passed onto individual conveyor belts. The sorting criteria can easily be adapted to the specific needs of each customer.

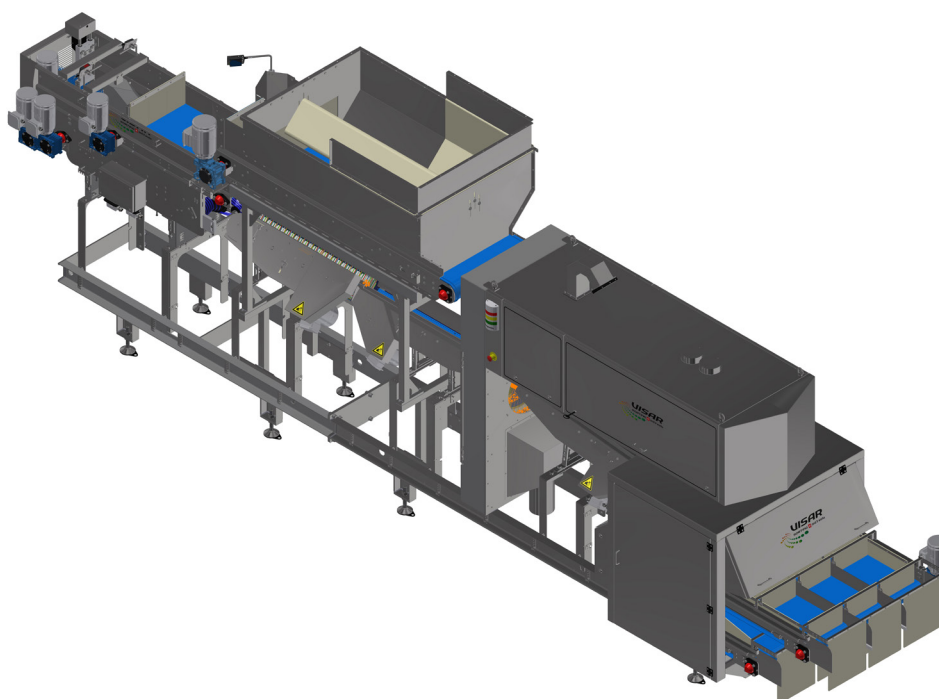

Technical data

Material:

- Stainless steel
- Food compliant

Switch cabinet:

- CE/UL standards
- Waterproof cabinet

Dimensions:

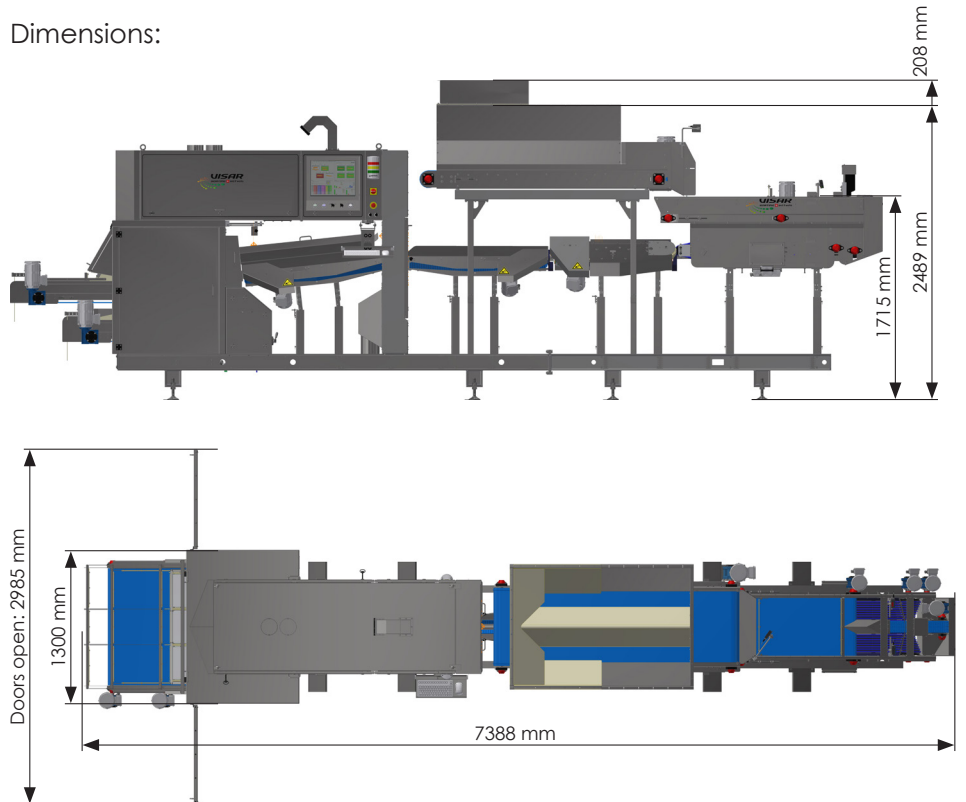

Our promise

- Highly precise sorting, calibration & weighing
- Swiss quality
- Easy handling
- Low production and maintenance costs
- Same harvest - more yield
- Quick and easy cleaning
- Efficient remote maintenance
- Competent and fast service
- Customized solutions
- Less food waste

For demonstrations & more information:

Contact us now!
+41 21 887 03 01

Visar Sorting Sàrl
La Tuilière 8
CH-1047 Oppens
T: +41 21 887 03 01
info@visar-sorting.com

Version: 2022.V1 / We reserve the right to make changes in technology, form, colour, equipment and price. Illustrations may vary.

www.visar-sorting.com